

## Rapid lock pull rings, galvanised

Rapid lock pull rings [f.lyn] are electro-galvanised and used for fast, tight assembly of duct systems.

Fitted with an insert which provides a dust-resistant joint and provides stability to the duct system, ensuring electrical conductivity through the assembly.

2 and 3 mm duct systems are fitted with a rapid lock pull ring with an insert which facilitates a larger size.

A silicon insert is required for temperatures above 80°C, which can tolerate temperatures up to 275°C.

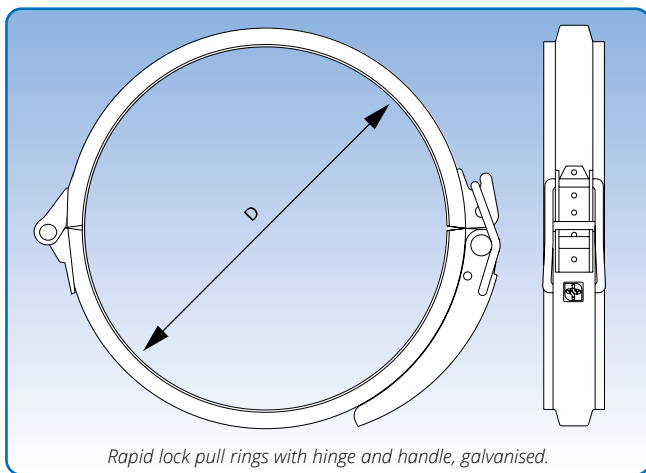

Diameter: ø80 - ø400 mm.

Handle is extended and made of a strong material for hand operation of rapid lock pull rings. The powerful steel spring ensures high quality opening/closing mechanism and long service life.

Supplied individually.

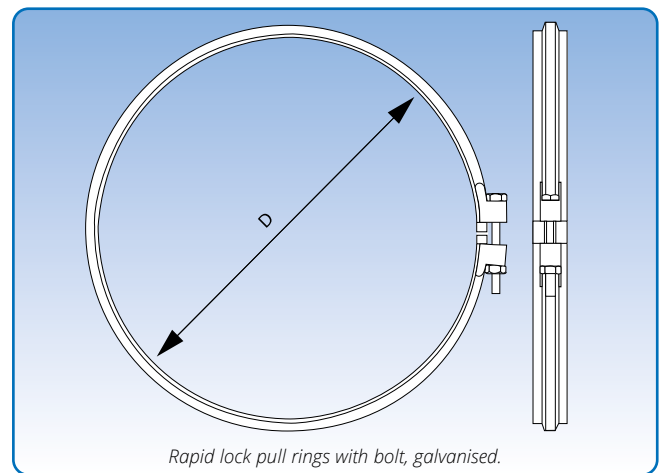

Diameter: ø425 - ø800 mm.

Supplied individually with nuts and bolts.

Rapid lock pull rings with hinge and handle, galvanised.

Item no.	D mm	Weight kg
1670013	80	0,19
1671013	100	0,21
1672013	120	0,23
1673013	125	0,24
1674013	140	0,25
1675013	150	0,26
1676013	160	0,28
1677013	180	0,30
1678013	200	0,32
1679013	225	0,34
1680013	250	0,37
1680513	275	0,39
1681013	300	0,42
1682013	315	0,44
1682613	325	0,45
1683013	350	0,48
1683613	355	0,48
1683713	375	0,51
1684013	400	0,53

Rapid lock pull rings with bolt, galvanised.

Item no.	D mm	Weight kg
1684712	425	0,56
1685012	450	0,58
1685912	475	0,61
1686012	500	0,63
1687012	550	0,68
1688012	600	0,73
1689012	630	0,79
1690012	650	0,81
1691012	700	0,88
1692012	750	0,94
1693012	800	1,00